

MIXING STATION UNIVERSAL

FOR UNDERFLOOR HEATING MANIFOLDS



The mixing station supplies heating manifolds with the required flow rate and in the process regulates and monitors the flow temperature.

DESCRIPTION

The mixing station is a flexible and compact pump assembly for direct installation in heating manifolds. The station is used especially for avoiding installation of a second, costly low-temperature pipework between the boiler and underfloor heating manifold.

The boiler manifold and mixing valve for the underfloor heating loop in the central pump room can also be dispensed with.

When the mixing station is installed directly in the apartment at the heating manifold, adjustments can be performed decentrally for every apartment in accordance with the

individual needs of the user and the type of floor covering.

The station therefore guarantees optimal heating comfort for all occupants and ensures safe operation of the system thanks to the external safety temperature limiter. The mixing station can be combined ideally with heating manifolds (TacoSys or others) together with radiator heating systems.

ADVANTAGES

Compact

- Comes equipped with all the necessary valves and components

Secure

- Intrinsic safety of station with external safety temperature limiter

Simple

- Simple adjustment and reading of the required flow temperature

Efficient

- Energy savings thanks to high-efficiency pump

Flexible

- The center distance between the flow and return can be adjusted flexibly through the use of eccentric connectors

INSTALLATION POSITION

Left-, right-, and over-head assembly is possible at the hot water inlet in front of the heating manifold.

OPERATION

The required flow temperature can be preset at the heating manifold by means of the integrated thermostatic mixing valve and then regulated subsequently. The pump is switched off by an external safety temperature limiter if the flow temperature of approx. 50°C is exceeded.

BUILDING CATEGORIES

All building categories with integrated panel heating combined with radiator heating.

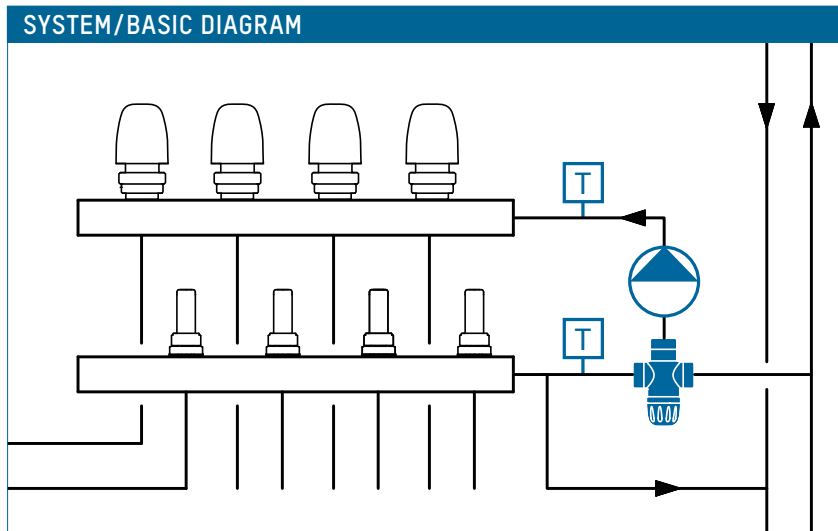

MIXING STATION UNIVERSAL

SPECIFICATION TEXT

See www.taconova.com

TECHNICAL DATA

General

- Operating temperature: -10 °C to + 70 °C
- Max. operating pressure $P_{B \max}$: 6 bar
- Adjustment range mixing valve: 20 – 50 °C
- Safety temperature limit 50 °C: $\pm 3\%$
- Residual pump head in accordance with flow rate and pressure loss diagrams

Materials

- Pipes: Stainless steel 1.4400
- Terminal nuts und eccentric connectors: Brass, nickel-plated
- Seals: EPDM O-rings

Flow media

- Heating water (VDI 2035; SWKI BT 102-01; ÖNORM H 5195-1)
- Water free of chemical additives

SYSTEM COMPONENTS

TacoDrive, TopDrive and NovaDrive electro-thermal actuators, room thermostats as well as distribution cabinets and heating manifolds: See separate datasheets.

TYPE OVERVIEW

Mixing station with Taco high-efficiency pump and external safety temperature limiter

Order no.	Delivery head
296.8666.001	7 m

DIMENSIONAL DRAWING

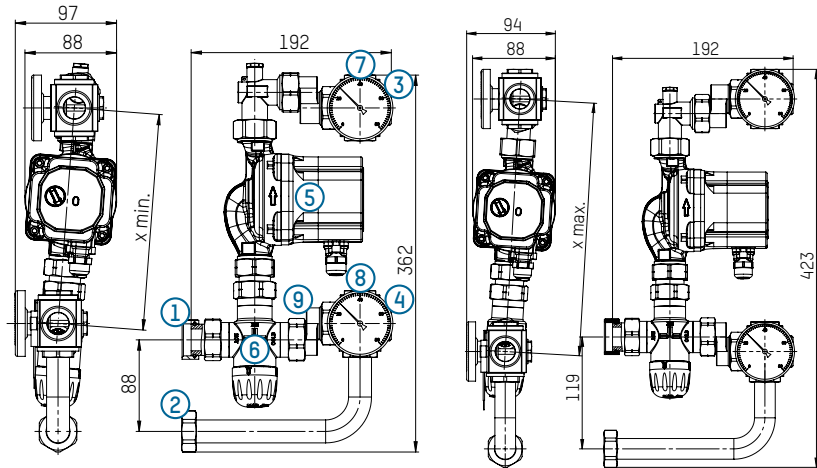

- | | |
|--|---|
| 1 Panel heating system flow (1" lock nut) | 6 NovaMix Value thermostatic mixing valve |
| 2 Panel heating system return (1" lock nut) | 7 Thermometer flow |
| 3 Manifold flow connection (1" outer thread) | 8 Thermometer return |
| 4 Manifold return connection (1" outer thread) | 9 Eccentric screw connection |
| 5 High-efficiency pump ES2 ADAPT 15-70 | |

Delivery condition dimensions X min = 207 mm

Adjustable using an eccentric connector to X max: 269 mm

Return flow connecting pipe adjustable between 92 mm and 123 mm

NOTE

Adjusting the mixing station

The mixing station is regulated by means of the integrated NovaMix Value mixing valve. The adjustment process is carried out when the circulating pump is running. All of the valves in the heating circuit must be fully open for adjustment. It may be necessary to remove the actuator drives.

- | | |
|--|---|
| 1 Check the flow temperature on the thermometer for the hot water flow. | 4 The set flow temperature should not exceed 45 °C. |
| 2 The flow temperature can be increased or decreased by rotating the blue plastic handle. | 5 A safety temperature limiter is located upstream from the circulating pump, which switches the pump off at approx. 50 °C. |
| 3 The flow temperature at the heating manifold may only be \leq the boiler flow temperature. | 6 Once adjustment is complete, note the corresponding flow temperature at the manifold or in the planning documents. |

**FLOW AND PRESSURE LOSS DIAGRAMS
MIXING STATION WITH OPEN VALVES AND TOPMETER**

