

RA 57 Actuators DDC for control voltage 0-10 Volt



Application

Anyone setting up heating, ventilation and cooling systems needs modern, economical technology that offers planning certainty: The DDC Actuators with «Direct Digital Control» for 0-10 V control voltage.

The proven, completely silent expansion material principle used in conjunction with intelligent control electronics and the unique routing system is the modern approach to secure, «accurate-to-the-degree» temperature control for interior spaces. They convert the output signal from a room thermostat into a continuously proportional lifting movement with perfect accuracy.

Intelligent, maintenance-free and silent in operation. The ideal components for modern, convenient building technology. Your future plans can include greater economy, reliability and more convenient control.

Room temperature regulation is effected by changes in the volume flow to:

- Heaters, convectors and radiators
- Ceiling cooling systems
- Fan convectors
- Manifolds for floor heating systems

Advantages

- Permanent continuous control
- Unique, intelligent routing system: The valve stroke is balanced by means of continuous target/actual comparison with the route determined by the control voltage
- Automatic self-adjustment with zero point recording evens out possible valve and installation tolerances.
- With watertight monitoring window for simple and secure function testing
- Silent, thermo-electrical principle
- No-wear, maintenance-free and functionally secure, offering long service life
- Sophisticated expansion material technology from automotive technology
- Harmonized design and compact dimensions for perfect integration in every room
- Outstanding price/performance ratio

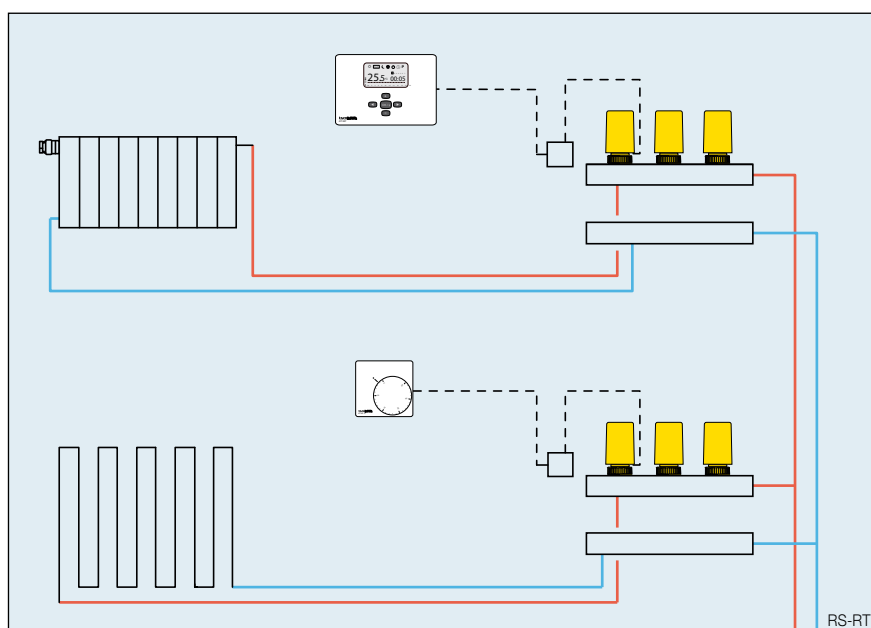

Functioning

Every divergence from the target room temperature causes the actuator to pass on a corresponding lifting motion to the valve.

Here, an expansion material element with PTC heating is moved. The supply voltage is 24 V AC, the signal voltage between 0 and 10 V DC. An adjustment routine stores the zero point after installation. For path measurement to regulate the stroke, a ferrite rod is inserted into a coil. The frequency of the coil changes according to the depth of insertion of the ferrite rod. The controller calculates the heating output of the PTC. The PTC is actuated with pulse packages via a triac.

RA 57 Actuators DDC for control voltage 0-10 Volt

Specification

Electro-thermal actuator DDC (Direct Digital Control) for the heating circuits of manifolds and radiator valves. Automatic self-adjustment with zero point recording. Visual indication of valve position. Silent operation. Electrical protection class II, Protection mode IP 44. With click connection, to fit Heimeier and compatible valves. CE conformity. Operating mode: No current closed Stroke: 3.5 mm Opening/closing time: approx. 60 sec./mm Operating temperature: -5° to +45° C Operating voltage: 24 V Control voltage: 0 to 10 V DC

Technical data

Type	No current closed
Operating voltage	24 V, 50/60 Hz
Control voltage	0-10VDC
Short-term starting current	270 mA
Constant current/output	70 mA/3 W
Stroke (overall)	min. 3.5 mm
Stroke (proportionally regulated)	2.5 mm
Connecting cable	60 cm; 3x0,35 mm ²
Ambient temp.	max. 45° C
Average setting time	60 sec./mm (from 3 V to 8 V)
Input resistance	150 K

Standards / approvals

Protection mode	IP 44
Protection class	II

The technical data conforms to the corresponding EN standards. The product bears the CE conformity mark.

Type overview / Order no.

24 V	To fit valves* from:	Function	Fixing
257.1355.500	Heimeier / Strawa / Delphistherm u.a.	NC	M30 x 1,5

NC = (Normally Closed) Function no current closed

* Further customized versions for other valve tops on request. In case of doubt about valve compatibility, please consult Technical Service department.

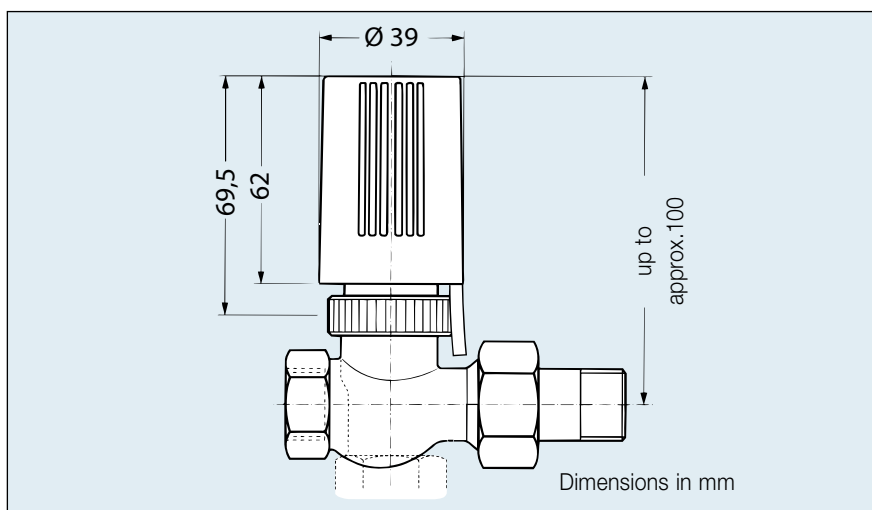
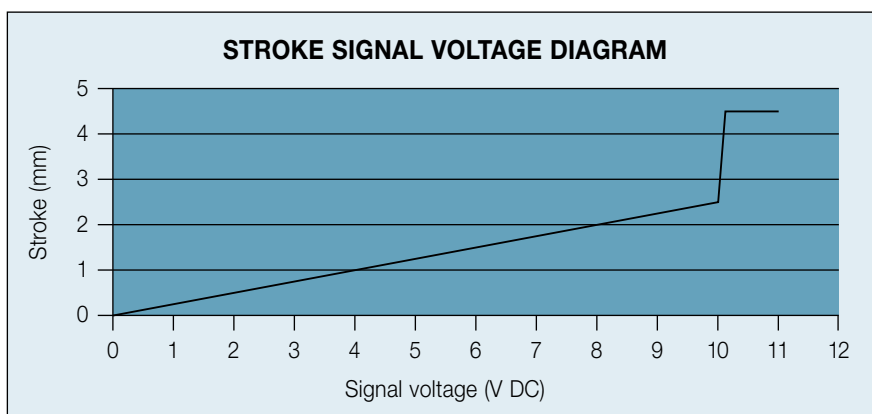

Click assembly for actuators

- Easy to assemble – Simple assembly even in cramped locations
- Individual – Suitable for all makes of valve*
- Logical – Preassembly possible
- Cost-effective – Rapid installation
- Practical – Just a simple click after hydraulic balancing
- Stable – Fixed using stainless steel detent
- Simple disassembly – Can be disassembled using simple tools



Subject to modification. R-RAD 12/07 pdf e