

TACOTHERM FRESH EXA

FRESH WATER STATION



OPERATING MANUAL

Contents

| | | |
|-----|--|----|
| 1 | About this document..... | 4 |
| 1.1 | Using these instructions..... | 4 |
| 1.2 | Symbols and notational conventions..... | 4 |
| 1.3 | Revisions and validity..... | 4 |
| 1.4 | Abbreviations | 5 |
| 1.5 | Other applicable documents | 5 |
| 2 | Safety information..... | 5 |
| 2.1 | Intended use..... | 5 |
| 2.2 | Improper use | 5 |
| 2.3 | Staff qualification..... | 6 |
| 2.4 | Safety measures | 6 |
| 2.5 | Residual risks | 6 |
| 2.6 | Prevention of damage to property | 7 |
| 3 | Tools and equipment | 7 |
| 4 | Scope of delivery | 7 |
| 5 | Product description..... | 8 |
| 5.1 | Fresh water station..... | 8 |
| 5.2 | Controller | 9 |
| 5.3 | Pumps..... | 9 |
| 6 | Storage and transport..... | 9 |
| 6.1 | Transport..... | 9 |
| 6.2 | Storage | 9 |
| 7 | Assembly | 10 |
| 7.1 | Requirements for the installation site | 10 |
| 7.2 | Wall-mounting the fresh water station | 10 |
| 8 | Installation | 11 |
| 8.1 | Installation requirements | 11 |
| 8.2 | Connecting a secondary circuit | 12 |
| 8.3 | Connecting a primary circuit | 13 |
| 8.4 | Electrical connection data | 14 |
| 9 | Commissioning..... | 14 |
| 9.1 | Checking the installation..... | 14 |
| 9.2 | Filling a primary circuit..... | 14 |
| 9.3 | Filling a secondary circuit | 15 |
| 9.4 | Checking the pump settings | 15 |
| 9.5 | Starting up the controller | 16 |
| 9.6 | Checking the water heating..... | 16 |
| 9.7 | Concluding the startup | 16 |
| 9.8 | Handing off the system to the operator..... | 16 |
| 10 | Operation | 17 |
| 11 | Error messages and malfunctions..... | 17 |
| 12 | Service and maintenance | 17 |
| 13 | Decommissioning | 17 |

| | | |
|------|-----------------------------------|----|
| 14 | Removal | 17 |
| 15 | Cleaning and care | 18 |
| 16 | Disposal | 18 |
| 17 | Spare parts and accessories | 18 |
| 18 | Technical data..... | 19 |
| 18.1 | Design and operating data | 19 |
| 18.2 | Dimensions and insulation | 20 |
| 18.3 | Connections..... | 20 |
| 18.4 | Storage conditions | 20 |
| 19 | Contact..... | 20 |
| 20 | Standards and regulations | 21 |

1 About this document

1.1 Using these instructions

These instructions are included with the product.



- ▶ Read the instructions carefully before use.
- ▶ Keep these instructions during the lifetime of the product.
- ▶ Ensure the instructions are available to operating, maintenance and service personnel at all times.
- ▶ Pass on the instructions to any subsequent owner, operator or user.

1.2 Symbols and notational conventions

Warning notices

Warnings are used in this manual to warn of damage to property and personal injury.

- ▶ Read and observe warnings.
- ▶ Follow all measures that are marked with the warning symbol and warning word.

| Warning symbol | Warning word | Meaning |
|---|--------------|---|
|  | WARNING | Danger to persons. Failure to comply can result in death or injury. |
|  | CAUTION | Danger to persons. Failure to comply may result in minor injury. |
| - | NOTE | Instructions for avoiding property damage or for understanding or optimizing the workflows. |

Additional symbols and notational conventions

Important information and technical notes are highlighted specifically to illustrate correct operation.

| Symbol | Meaning |
|---|--|
|  | means „Additional Information“. For understanding and for optimizing workflows |
| ▶ | Symbol for an action: You have to do something here. In case of a series of actions, make sure to observe the correct sequence. |

1.3 Revisions and validity

Valid for TacoTherm Fresh Exa storage loading stations constructed from 08/2013

| Document version | Date | Comment |
|------------------|---------|---------------------------------|
| Version 5 | 08/2015 | Current version on taconova.com |

1.4 Abbreviations

| Abbreviation | Meaning |
|--------------|---|
| DN | Diameter Nominal |
| G | Fastening thread, cylindrical, as per ISO 228 |
| R | Pipe thread/outer thread as per ISO 7/DIN 2999 |
| Rp | Pipe thread/inner thread as per ISO 7/DIN 2999 |
| PB | Max. operating pressure as per DIN 2401 |
| TB | Max. operating temperature as per DIN 2401 |
| kVS | Characteristic value in relation to a volume flow of 1 m ³ /h and a pressure loss of 1 bar at 100 % valve lift |

1.5 Other applicable documents

| Document | Comment |
|---|---------------------------------|
| Data sheet | Current version on taconova.com |
| Controller operating instructions (EA 1125) | Current version on taconova.com |

2 Safety information

2.1 Intended use

- ▶ The fresh water station should be used exclusively in combination with a storage tank for heating drinking water in closed heating systems.

INFORMATION



Any other use is deemed improper. The manufacturer is not liable for any resulting damages. The risk is borne solely by the user.

- ▶ Note all instructions in this manual and the applicable documents.
- ▶ Note the maximum operating limits: Section „18 Technical data“ on page 19

2.2 Improper use

INFORMATION



Any use other than in this manual and in the other applicable documents is improper. The manufacturer is not liable for any resulting damages. The risk is borne solely by the user.

- ▶ Direct connection of the fresh water station to a heat generation unit (for example a boiler or solar circuit) is prohibited.
- ▶ Do not use the fresh water station in the following areas:
 - Outdoors
 - Damp rooms
 - Rooms in which the use of electrical equipment is prohibited
 - Frost risk areas

2.3 Staff qualification

The fresh water station may only be installed, maintained and repaired by authorized, trained and qualified personnel.

- ▶ Use only qualified personnel who have the necessary training and experience to identify risks and avoid potential hazards.
- ▶ Define responsibilities for personnel in accordance with their qualifications and job description.
- ▶ Ensure that the following requirements are fulfilled:
 - Employees have read and understood these operating instructions.
 - Employees have been informed about possible dangers.
 - Employees know and observe the applicable accident prevention and safety regulations.

2.4 Safety measures

- ▶ Keep the work area clean and free of obstructing objects.
- ▶ Ensure sufficient lighting.
- ▶ Keep children, pets and unauthorized persons away from tools and assembly areas.
- ▶ Store hazardous substances and liquids safely and not in the vicinity of the station.
- ▶ Only allow qualified personnel to work on the system.

Materials and components used on site must be suitable for the intended purpose without any restrictions; moreover, they must be inspected or approved by the manufacturer and conform with the applicable laws, standards, guidelines and specifications.

- ▶ Use only appropriate materials and components.
- ▶ Do not make any unauthorized changes to the fresh water station.

The controllers for the fresh water station and the pumps are operated with electric power.

- ▶ Disconnect the system from the mains before beginning maintenance, service and repair work and secure against reconnection.

Operation

- ▶ If damage occurs to the system:
 - Put the system out of service.
 - Do not continue to operate the system.

Maintenance and repair

- ▶ Never allow the operator to remove the hood and make repairs.
- ▶ Only allow qualified personnel to make repairs to the system.
- ▶ Only use original spare parts.

Fire prevention

- ▶ Note applicable fire protection regulations and valid building codes / building regulations. Especially in the following cases:
 - When breaking through ceilings and walls
 - In rooms with special / stricter requirements for fire prevention measures

2.5 Residual risks

Water quality

- ▶ Take account of corrosion protection and sludge formation in the planning according to DIN 1988-7 and water analyses (according to DIN 50930 Part 6).
- ▶ Regularly perform checks according to DIN 1988.

2.6 Prevention of damage to property

On site heating system

- ▶ Flush the on site heating system sufficiently prior to installing the station.

Safety equipment in the primary circuit

- ▶ Please observe VDI Directive 2035 (Sheet 1 and 2) for planning, assembly and operation.
- ▶ Schedule and install the safety valve in the primary circuit.

Safety equipment in the secondary circuit

The on site system has a safety valve in the secondary circuit.

- ▶ Provide a discharge pipe according to DIN 1988 for the secondary circuit.

Repairs

- ▶ Only allow qualified personnel to make repairs to the system.
- ▶ Only use original spare parts.

Materials and components used on site must be suitable for the intended purpose without any restrictions; moreover, they must be inspected or approved by the manufacturer and conform with the applicable laws, standards, guidelines and specifications.

- ▶ Use only appropriate materials and components.
- ▶ Do not make any unauthorized changes to the fresh water station.
- ▶ If damage should occur to the system: Do not continue to operate the system.

3 Tools and equipment

- ▶ Do not use pipe wrenches when assembling valves and for screw connections with wrench flats.
- ▶ Use conventional tools and materials.

4 Scope of delivery

| Materials | Number | Comment |
|---|--------|---|
| TacoTherm Fresh Exa Fresh Water Station | 1 | With circulation |
| Hanger bolts | 4 | Mounting material for wall installation |
| Dowels for masonry | 4 | Mounting material for wall installation |
| Controller | 1 | Pre-assembled ready for connection |
| Shut-off valves | 3 | Enclosed |
| Ball valves | 2 | Enclosed |
| Hood | 1 | Preassembled |
| Operating manual | 1 | Enclosed |
| Controller operating instructions | 1 | Enclosed |
| Pump documentation | 3 | Enclosed |

5 Product description

5.1 Fresh water station

Structure

INFORMATION



The fresh water station is fully preassembled and supplied with ready-to-connect wiring.

The components of the fresh water station are assembled on a base plate.

Components

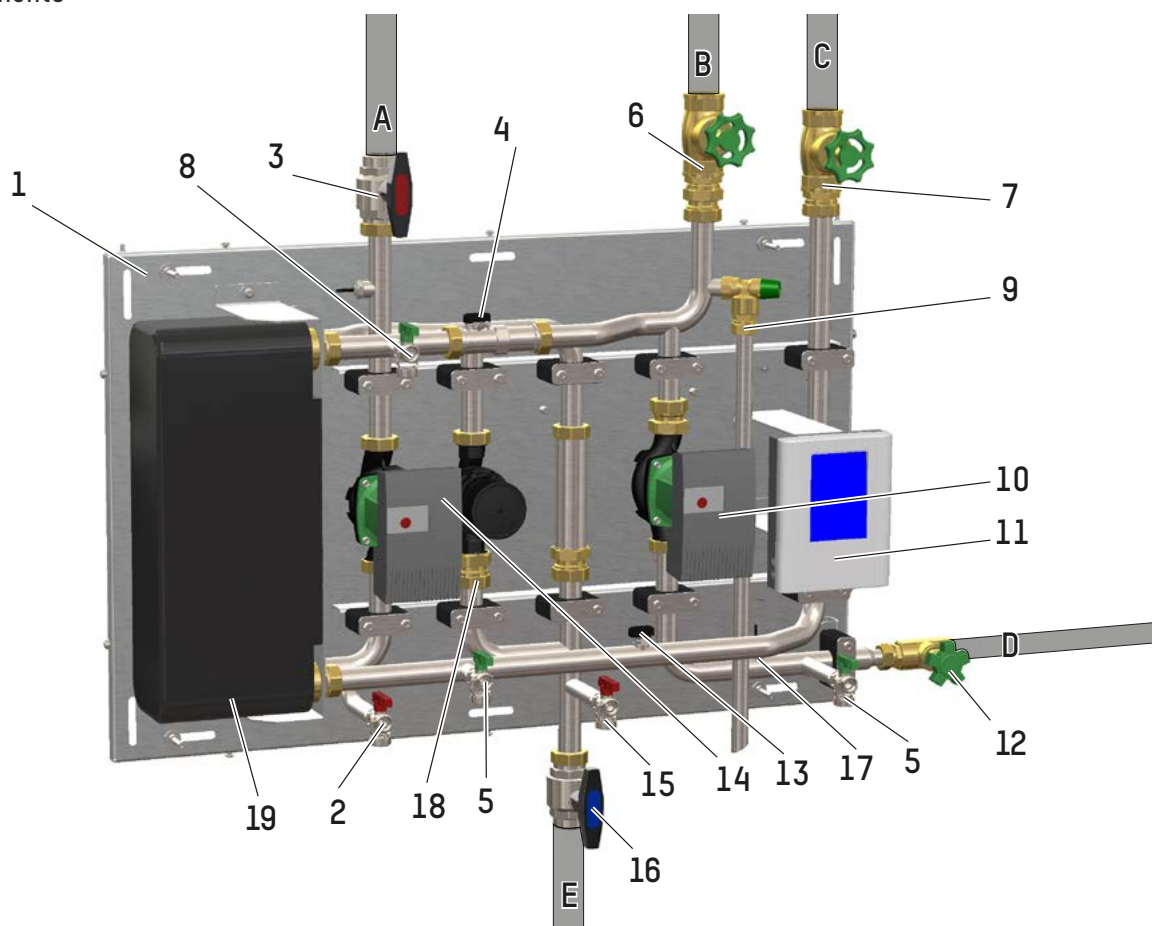



Figure 1 TacoTherm Fresh Exa fresh water station with circulation

| | | | |
|----|---|----|--|
| 1 | Base plate | 14 | Primary pump II (Wilo) |
| 2 | Draining cock and filling valve primary | 15 | Draining cock and filling valve primary heating return |
| 3 | Ball valve primary heating return | 16 | Ball valve heating return |
| 4 | Flow sensor | 17 | Temperature sensor circulation |
| 5 | Draining cock and filling valve secondary | 18 | Primary pump I (Laing) |
| 6 | Shut-off valve with backflow preventer cold water | 19 | Plate heat exchanger |
| 7 | Shut-off valve hot water | 20 | Hood and side panels (not shown) |
| 8 | Draining cock and filling valve secondary | | |
| 9 | Safety valve with discharge pipe | A | Primary heating flow |
| 10 | Circulation pump (Wilo) | B | Secondary cold water connection |
| 11 | Controller | C | Secondary hot water connection |
| 12 | Shut-off valve circulation | D | Circulation connection |
| 13 | Temperature sensor hot water | E | Primary heating return |

Function

The TacoTherm Fresh Exa fresh water station for large installations heats drinking water on demand in accordance with the cyclical principle in conjunction with a storage tank for existing and new heating systems, solid fuel boilers, heat pumps and solar systems etc. ...

Type plate

| | |
|---|---|
|  | |
| Typ: | Frischwarmwasserstation TacoTherm Fresh Exa Artikelnummer: 273.5530.XXX |
| Primärseitig | -Max. Betriebstemperatur: 95 °C -Max. Betriebsdruck: 3 bar |
| Sekundärseitig | -Max. Betriebstemperatur: 95 °C -Max. Betriebsdruck: 10 bar |
| Elektrische Anschlussdaten | -Netzspannung: 230 VAC ±10% -Netzfrequenz: 50...60 Hz -Schutzart: IP 40 |
| Leistungsaufnahme | 14...440W, (0.61...1.91 A) |

Type

Fresh Water Station
TacoTherm Fresh Exa
Article Number: ...

Primary side

- Max. operating temperature: 95 °C
- Max. operating pressure: 3 bar

Secondary side

- Max. operating temperature: 95° C
- Max. operating pressure: 10 bar

Electrical connection data

-Mains voltage: 230 VAC +/-10%
-Mains frequency_ 50...60 Hz
-Protection type: IP 40

Power consumption

14...440W, (0.61...1.91 A)

5.2 Controller

Product description according to external instructions for controllers.

5.3 Pumps

Product description according to documentation for pumps.

6 Storage and transport

6.1 Transport

- ▶ At least two persons are needed to transport the fresh water station.
- ▶ The fresh water station may only be transported horizontally (controller facing upward).

For longer journeys:

- ▶ Transport the fresh water station in its original packaging.
- ▶ Transport the station using suitable lifting equipment and means of transport.

6.2 Storage

- ▶ Store the fresh water station for long periods in dry, dust-free and frost-free rooms only and in its original packaging.

7 Assembly

7.1 Requirements for the installation site

CAUTION



There is a risk of injury and damage to the wall and fresh water station if the fresh water station falls down!

- ▶ Make sure the wall is sufficiently load-bearing.
- ▶ Consult a structural engineer if necessary.

- ▶ Make sure that the installation location is near the storage tank.
- ▶ Make sure that the room is dry and frost-free.
- ▶ Make sure a mains connection of adequate performance is available:
 - with protection
 - Positioned to the right of the fresh water station
 - At max. distance of 1.5 m to the fresh water station

7.2 Wall-mounting the fresh water station

CAUTION



There is a risk of injury if the fresh water station falls down!

Weight of fresh water station without water: approx. 75 kg

- ▶ Remove the fresh water station from its packaging using at least two persons.
- ▶ Position the fresh water station with the base plate on a level surface.
- ▶ Unscrew the hood and side panels at the side and remove.

NOTE

There is a risk of damage to the fresh water station if it falls down!

- ▶ For wall mounting, use all four mounting points on the base plate.
- ▶ Use the supplied mounting material.
- ▶ Drill holes for all mounting points.
 - Size: **see diagram**.

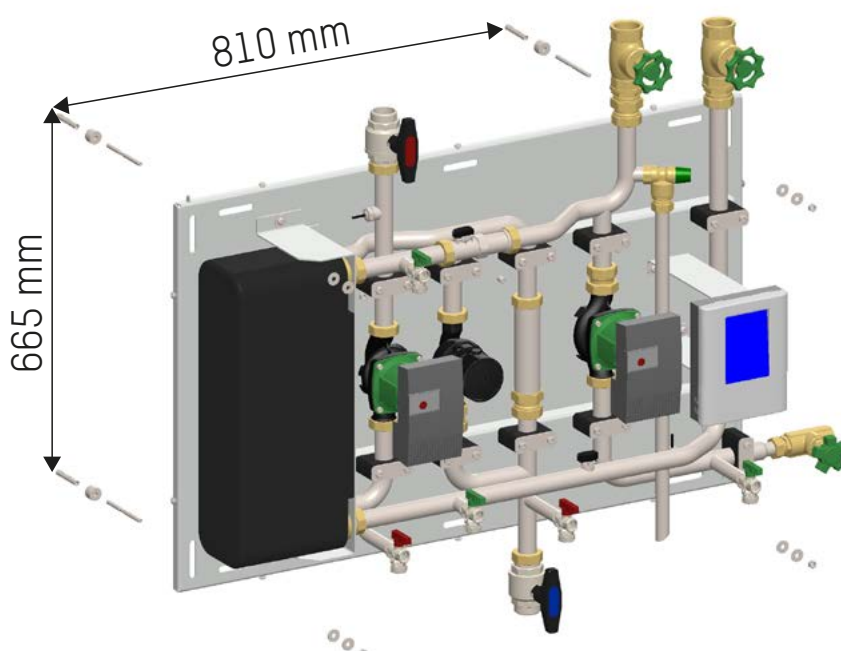

Figure 2 Mounting points

- ▶ Insert the supplied dowels into the holes.
 - Use dowels appropriate for different masonry if necessary.

CAUTION



There is a risk of injury if the fresh water station falls down!
 Weight of fresh water station without water: approx. 75 kg
 ▶ At least three persons are needed to assemble the fresh water station.

- ▶ Screw in and tighten the 4 hanger bolts supplied in the drill holes.
 - ▶ Position the fresh water station and fix it to the wall using at least two people.
 - ▶ Have another person screw in the hanger bolts.
- The fresh water station is now assembled.

8 Installation

8.1 Installation requirements

- ▶ Make sure that the existing piping (pipes and connections) is checked for leaks.
- ▶ Make sure that flexible connecting cables are not twisted or kinked.
- ▶ Make sure that the existing piping is adequately insulated.
- ▶ Make sure that the safety valve drain is connected.
- ▶ Install rinsing valves in the cold water, hot water and circulation pipe.
- ▶ Flush the cold water, hot water and circulation pipe.

NOTE

The fresh water station may be damaged as a result of water hammers!
 Closing and opening the water intake points too quickly may lead to water hammers.
 ▶ Install water hammer arrestors on site in accordance with the manufacturer's instructions.

NOTE

Increased calcification is possible depending on the water composition and operating conditions.
 ▶ Take account of corrosion protection and sludge formation according to DIN 1988-7 and water analyses (according to DIN 50930 Part 6).

HINWEIS!

Fehlfunktion durch eingebaute Zirkulationsventile
 ▶ Prüfen, dass keine Zirkulationsventile sekundärseitig installiert sind.

NOTE

Malfunction by built-circulation valves
 ▶ Check that no circulation valves are installed on the secondary side.

8.2 Connecting a secondary circuit

- ✓ On site piping sufficiently flushed
- ✓ Pipes to outlets closed
- ✓ Secondary cold water connection closed

8.2.1 Connecting a cold water pipe

- ✓ Safety equipment available on site
- ✓ Cold water supply closed

INFORMATION



A safety valve for intrinsic safety of the system is installed on the secondary side.

- ▶ Install an appropriate discharge pipe.
- ▶ Run discharge pipe so that there is no increase in pressure when the safety valve is actuated.
- ▶ Attach a plate to the discharge pipe with the following label: **Water may leak from the discharge pipe during heating for safety reasons! Do not close!**

INFORMATION



If mains pressure exceeds max. allowable operating pressure:

- ▶ Install and adjust a pressure regulator in the cold water supply (according to external instructions and DIN 1988)
- ▶ Install suitable water filters in the cold water supply.
- ▶ Run the piping to the fresh water station as per the planning.
- ▶ Install a shut-off valve (6).
- ▶ Connect the cold water pipe to connection (B).

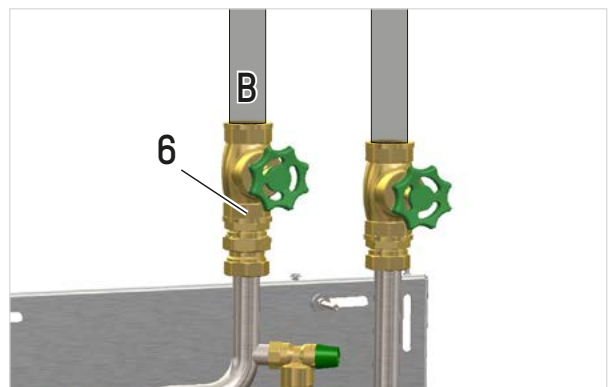

8.2.2 Connecting a hot water pipe

- ✓ Safety equipment available on site

CAUTION



There is a risk of scalding if the storage temperatures are allowed to exceed 60 °C!

- ▶ Install a suitable mixing valve as anti-scalding protection in the hot water pipe behind the fresh water station.
- ▶ Set the response temperature of the mixing valve to the same value as the max. hot water temperature.

NOTE

Pitting corrosion may cause damage to the pipes!

Copper ions dissolved in water can cause pitting corrosion on steel.

- ▶ Please note the technical regulations for mixed material installations. Install base metals before more precious metals in the direction of water flow.

TACOTHERM FRESH EXA

- ▶ Run the piping to the fresh water station as per the planning.
- ▶ Install a shut-off valve (7).
- ▶ Connect the secondary hot water pipe to connection (C).

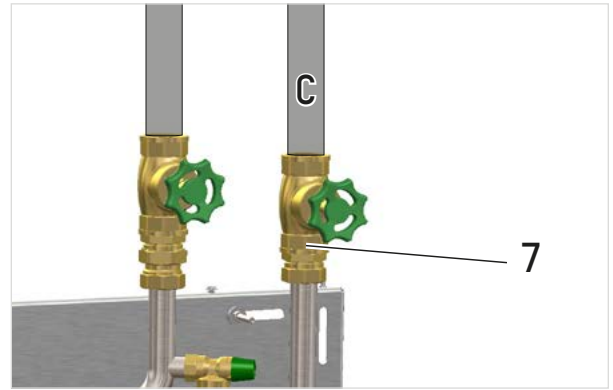

8.2.3 Connecting a circulation pipe

- ▶ Run the piping to the fresh water station as per the planning.
- ▶ Install a shut-off valve (12).
- ▶ Connect the circulation pipe to connection (D).

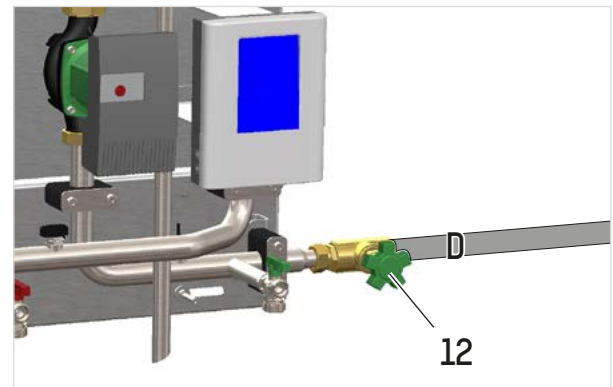

8.3 Connecting a primary circuit

- ▶ Install a suitable safety assembly (according to DIN 4753) with shut-off valve.

8.3.1 Connecting a primary heating flow

- ▶ Install a ball valve (3).
- ▶ Connect the primary hot water flow to connection (A).

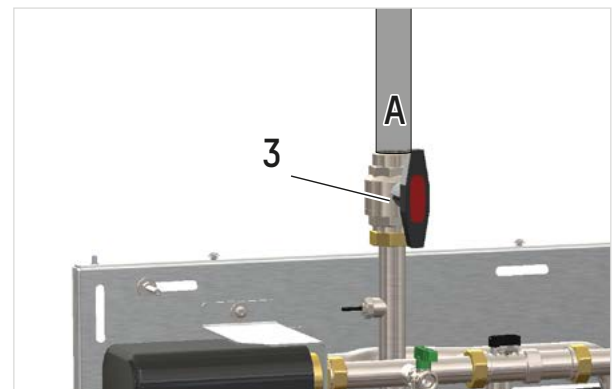

8.3.2 Connecting a primary heating return

- ▶ Install a ball valve (16).
- ▶ Connect the primary hot water return to connection (E).

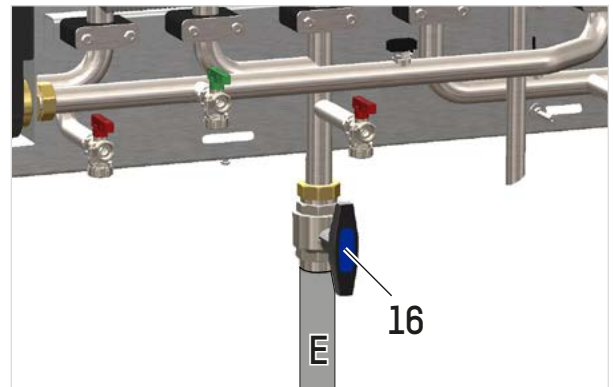

8.4 Electrical connection data

INFORMATION



The fresh water station is not protected against shorting and the like. Electrical protection is country-specific and up to the user.

- ▶ Perform electrical protection on country-specific basis.
- ▶ Make sure that the electrical connection is supplied on site and complies with technical requirements.
- ▶ Plug the power cable for the controller (country specific or with adapter) into the socket.

9 Commissioning

9.1 Checking the installation

- ✓ Water quality checked

NOTE

The pumps may be damaged from running dry!

- ▶ Make sure that the piping is properly sealed.
- ▶ Make sure that the pump is filled properly.

NOTE

Pumps may be damaged due to excess pressure!

- ▶ Protect valves from being closed accidentally following installation using a lead seal.

- ▶ Check the following prior to startup:
 - Completeness of piping in the fresh water station
 - Piping for leak tightness
 - Correct installation of safety-related components
 - Water quality

9.2 Filling a primary circuit

- ✓ Installation checked

- ▶ Note backflow preventer in storage return.
- ▶ Fill and rinse the primary circuit.
- ▶ Fill and vent the storage tank.
- ▶ Vent pump, pipes and storage tank in primary circuit..

9.3 Filling a secondary circuit

- ✓ Installation checked
- ▶ Fill and vent the secondary circuit.
- ▶ Vent the fresh water station by running water (on the cold and hot water sides).
- ▶ Vent the circulation pump.

9.4 Checking the pump settings

9.4.1 Checking the setting of the primary pump II

The factory setting for the primary pump II is set to **external**.

- ▶ Make sure that the primary pump II is adjusted at the factory (see diagram).

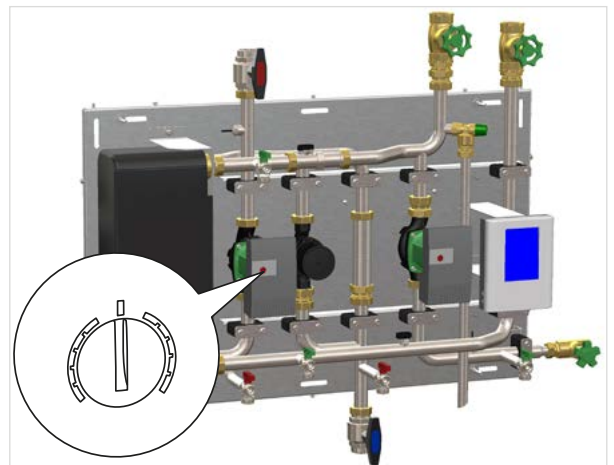

9.4.2 Checking the setting of circulation pumps

The factory setting for the circulation pump is $\Delta p-c$ (position 8).

- ▶ Make sure that the circulation pump is adjusted at the factory (see diagram).

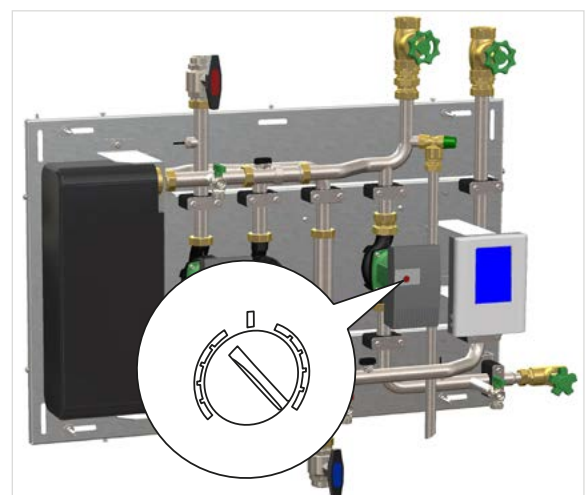

9.5 Starting up the controller

- ✓ Primary circuit filled and vented
 - ✓ Secondary circuit filled and vented
 - ✓ System and piping checked for leak tightness
- ▶ Connect controller (according to external instructions for controllers).

NOTE

- Pumps may be damaged due to excess pressure!**
- ▶ Do not close the shut-off valves between the fresh water station and the safety valves while the primary circuit pump is in operation.

- ▶ Start up the controller.

INFORMATION



- Regler ist werkseitig eingestellt.
- ▶ To change the controller settings, proceed as per the external instructions for controllers

9.6 Checking the water heating

- ✓ Controller started up
- ▶ Run hot water.
- ▶ Check the water heating.
- ▶ Set the primary circuit pump to highest power level if necessary.

9.7 Concluding the startup

- ✓ System and piping checked for leak tightness
 - ✓ Controller started up
 - ✓ Water heating checked
- ▶ Clean the inside of the fresh water station of construction dirt.
- ▶ Attach the hood and screw in place at the side.
- ▶ Clean the outside of the system of construction dirt.

9.8 Handing off the system to the operator

- ▶ Instruct the system operator in the operation of the system (in accordance with operating instructions for controllers). Take note of the safety and maintenance periods.
- ▶ Note the defined parameters at handover in the log.
- ▶ Pass on all instructions to operators:
 - This Operating manual
 - Operating instructions for components (controllers, etc. ...)

INFORMATION



- Operators:**
- ▶ Bring all instructions to the place of installation of the fresh water station or keep in the vicinity of the fresh water station.

10 Operation

- ▶ Operate the system according to external instructions for controllers.

11 Error messages and malfunctions

Error messages appear on the display of the controller (see external instructions)

- ▶ Contact qualified personnel in case of error messages and faults.

CAUTION



Leaks can lead to injury or damage to property!

- ▶ Only allow qualified personnel to perform troubleshooting.

12 Service and maintenance

- ▶ Have the following points checked once a year by the operator and suitable qualified personnel:
 - Function
 - Leak tightness of the system and piping
 - Safety valve
 - Connection cable
 - Water quality
 - Visual inspection
 - Wall mounting

WARNING!



Interference with electrical wiring may result in injury and damage to property!

- ▶ Only allow qualified personnel to perform maintenance.

- ▶ Perform maintenance once a year.

13 Decommissioning

- ▶ Disconnect the controller for the fresh water station from the mains.
- ▶ Close the water flow and return.
- ▶ Drain the primary and secondary circuit.

14 Removal

- ✓ Decommission the fresh water station.
- ▶ Undo the screws on the fresh water station.

CAUTION



There is a risk of injury if the fresh water station falls down! !

Weight of fresh water station without water: approx. 75 kg

- ▶ At least three persons are needed to disassemble the fresh water station.

- ▶ Undo the screws on the base plate. At least two persons are needed to hold it.
- ▶ Remove the fresh water station from the wall and set aside in a suitable location. Cover if necessary. The fresh water station is now disassembled.

15 Cleaning and care

- ▶ Clean and maintain the controller according to the information in the external instructions.
- ▶ Do not use aggressive cleaning agents on the hood.
- ▶ Keep the hood clean, remove coarse dirt, dust and moisture regularly.

16 Disposal

The fresh water station contains components that comply with the European RoHS Directive 2002/95/EC for restricting the use of specific hazardous materials in electrical and electronic equipment.

- ▶ Do not dispose of the system and components in normal household waste.
- ▶ Dispose of the system and components at appropriate collection centers.

-or-

- ▶ Return the system to the seller or supplier.

17 Spare parts and accessories

Spare parts are available from taconova.com

- ▶ The following information is needed for ordering spare parts:
 - Article number
 - Production date

Article number: See website taconova.com

18 Technical data

18.1 Design and operating data

18.1.1 Fresh water station

| Parameter | TacoTherm Fresh Exa |
|--|---|
| Rated performance | 125 l/min |
| Fresh water temperature | 60 °C (at storage temperature of 70 °C) |
| Max. operating temperature (primary) | 95 °C |
| Max. operating temperature (secondary) | 95 °C |
| Max. operating pressure (primary) | 3 bar |
| Max. operating pressure (secondary) | 10 bar |
| Max. return temperature | 30 °C |
| Discharge pressure DN 15 safety valve | 10 bar |
| Pressure loss primary | See diagram in data sheet |
| Pressure loss secondary | See diagram in data sheet |
| Plate heat exchanger | Stainless steel 1.4401, copper-soldered |
| Primary circuit pump I | Laing E6-PWMS 25/180 |
| Primary circuit pump II | Wilo Stratos Para 25/1-12 (180mm) |
| Circulation pump | Wilo Stratos Para Z 25 / 1-8 (180mm) |
| Pressure loss primary | See data sheet |
| Pressure loss secondary | See data sheet |
| Measurement range for dispensing flow rate | 1 to 125 l/min |

Electrical connection data

| Parameter | TacoTherm Fresh Exa |
|-------------------|---------------------|
| Mains voltage | 230 VAC ± 10 % |
| Mains frequency | 50...60 Hz |
| Power consumption | 14 – 440 W |
| Protection type | IP 40 |

18.1.2 Controller

Technical data according to external instructions for controllers.

18.2 Dimensions and insulation

| Parameter | TacoTherm Fresh Exa |
|------------------------------|---|
| max. W x H x D insulated | 1176 mm x 746 mm x 306 mm |
| Weight without water content | Approx. 125 Kg |
| Hood | Designer hood made from galvanized sheet metal, powder-coated |
| Insulation (optional) | Pipes with 25 mm Armaflex |

18.3 Connections

| Connection | TacoTherm Fresh Exa |
|----------------------------------|---------------------|
| Hot water / storage water flow | DN 40 IG |
| Hot water / storage water return | DN 40 IG |
| Secondary connection | TacoTherm Fresh Exa |
| Circulation | DN 25 IG |
| Cold water | DN 40 IG |
| Hot water | DN 40 IG |

See data sheet for performance charts.

18.4 Storage conditions

- Store dry, dust and frost-free in original packaging.

19 Contact

Taconova Group AG
 Neunbrunnenstrasse 40
 CH-8055 Zurich
 T +41 44 735 55 55
 F +41 44 735 55 02
 group@taconova.com
 taconova.com

Taconova GmbH
 Rudolf-Diesel-Strasse 8
 D-78224 Singen
 T +49 7731 98 28 80
 F +49 7731 98 28 88
 deutschland@taconova.com

20 Standards and regulations



Hydraulischer Abgleich | Verteilertechnik | Systemtechnik | Armaturentechnik

CE KONFORMITÄTSERKLÄRUNG DECLARATION OF CONFORMITY DECLARATION DE CONFORMITE

Wir

We

Nous

(Name des Anbieters) (supplier's name) (nom du fournisseur)

Taconova Group AG

**erklären in alleiniger Verantwortung, dass das Produkt
declare under our sole responsibility that the product
declaronos sous notre seule responsabilite que le produit**

TacoTherm Fresh EXA C

Typen: 273.5530.000 // 273.5530.382 // 273.5531.000 // 273.5531.382
Nennweiten: DN 40

(Bezeichnung Typ oder Modell, Los-, Chargen- oder Seriennummer)
(name, type or model, lot, batch or serial number)
(nom, type ou modele, no de lot, d'echantillon ou de serie)

**auf das sich diese Erklärung bezieht, mit der/den folgenden Norm(en) oder normativen Dokument(en)
übereinstimmt
to which this declaration relates is in conformity with the following standard(s) or other normative
document(s)
auquel se réfère cette déclaration est conforme à la (aux) norme(s) ou autre(s) document(s) normatif(s)**

EN 13445 // EN 60335-1 // EN 60730-1: 2000/A2: 2008 // EN 60730-2-9: 2010 //
EN 61000-3-2: 2006 // EN 61000-3-3: 2008 //

(Titel und/oder Nummer sowie Ausgabedatum der Norm(en) oder der anderen normativen Dokumente)
(title and/or number and date of issue of the standard(s) or other normative document(s))
(titre et/ou no et date de publication de la (des) norme(s) ou autre(s) document(s) normatif(s))

**Gemäss den Bestimmungen der Richtlinie(n),
following the provisions of Directive(s),
conformement aux dispositions de(s) directive(s)**
(falls zutreffend) (if applicable) (le cas echeant)

Pressure Equipment directive (PED) 97/23/EC
Low Voltage directive 2006/95/EC
Directive for electromagnetic compatibility 2004/108/EC

(Ort und Datum der Ausstellung) (Name und Unterschrift oder gleichwertige Kennzeichnung des Befugten)
(Place and date of issue) (name and signature or equivalent marking of authorized person)
(Lieu et date) (nom et signature du signataire autorise)

Urdorf, den 03.03.2014

Philipp Hauser
Head Product Development

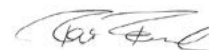
René Freudrich
Head Product Management

