

NOVAMIX STANDARD

THERMOSTATIC MIXING VALVE



ADVANTAGES

- Constant temperature of the water at the outlet
- Automatic mixing function without the need for auxiliary power
- Infinite regulation of the nominal temperature in 2 ranges: 20 – 40 °C / 30 – 70 °C
- Protection against scalding; the NovaMix Standard 70 FS model closes tightly
- In the functional area: polished surfaces to prevent limescale deposits
- Can be used in panel heating systems and for loading storage tanks by means of solid-fuel boilers

Maintaining constant mixing temperatures and limiting temperatures in hot water systems

DESCRIPTION

The automatic thermostatic mixing valve NovaMix Standard ensures a constant temperature of the mixed water at the outlet when used as the central mixing device.

The NovaMix Standard is mainly used in sanitary applications as a regulating device for reducing the temperature of the water coming out of hot water storage tanks. It can also be used in numerous other applications requiring a constant mixing temperature, for example as a mixing unit for constant water mixing temperatures in panel heating systems and for loading storage tanks by means of solid-fuel boilers.

INSTALLATION POSITION

Any.

OPERATION

Standard design:

A thermostatic cartridge and a return spring ensure the constant blend temperature at the outlet.

Thanks to the design of the mixing valve, the thermostatic cartridge can be easily replaced in the installed valve if the performance decreases, which occurs due to normal wear and tear.

Special design NovaMix Standard 70 FS (Fail Safe):

In the case of cold water failure, the hot water supply shuts off automatically and hermetically.

BUILDING CATEGORIES

For pipe installations in drinking water and heating area:

- Apartment blocks, housing estates, multiple dwelling units
- Residential care facilities, hospitals
- Administration and service buildings
- Hotels and restaurants, industrial kitchens
- School buildings and sports facilities
- Commercial and industrial buildings

SYSTEM/BASIC DIAGRAM

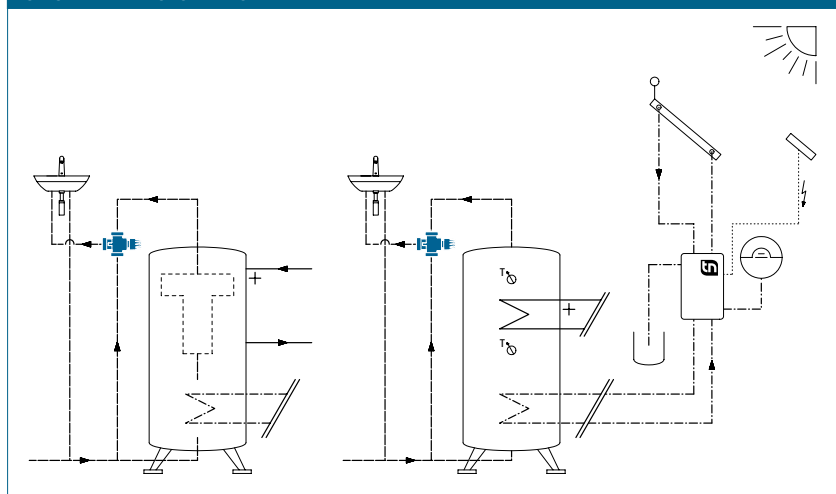

NOVAMIX STANDARD | THERMOSTATIC MIXING VALVE

SPECIFICATION TEXT

See www.taconova.com

TECHNICAL DATA

General

- Operating temperature $T_{0,max}$: adjustable temperature ranges, k_{VS} values and dimensions as per the relevant tables
- Operating temperature $T_{0,max}$ with check-valve (CV): 90 °C
- Max. operating pressure $P_{0,max}$: 10 bar
- Min. operating pressure $P_{0,min}$: 0,5 bar
- Working pressure (dynamic): max. 5 bar
- Constant inlet pressure differential: max. 2 bar
- Temperature stability for mixing: max. 3 K (for change in hot water temperature: 15 K)
- Locking function in the event of failure of the cold water supply
- Noise class 2
- Installation position: can be installed in any position

Material

- Housing and inner parts: brass (resistant to dezincification)
- Seals: EPDM
- In the functional area: polished surfaces to prevent limescale deposits

Fluids

- Heating water (VDI 2035; SWKI BT 102-01; ÖNORM H 5195-1)
- Potable water (DIN 1988-200)

Special application

- Diverting function possible (inflow via a mixing gate)

APPROVALS / CERTIFICATES

- DVGW (UBA hygiene conformity), ACS, PZH

NOTE

The brochure „NOVAMIX ONE RANGE - NEW APPLICATIONS“ contains additional information on the various applications of Taconova mixing valves.

DIMENSIONAL DRAWING

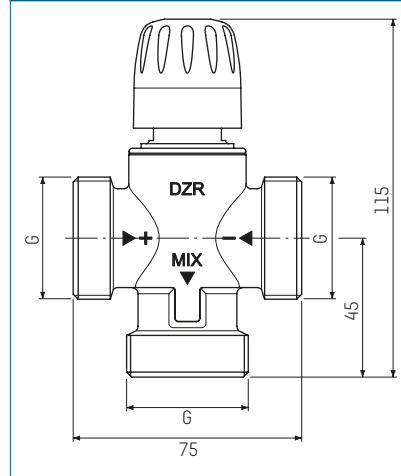

INFORMATION

If the handwheel of the mixing valve is fully open, the mixing element will not work. As a result, the outlet temperature may be above the controllable temperature range and may be approximately the same as the hot water inlet temperature.

TYPE OVERVIEW

NovaMix Standard 70 / 40 | Thermostatic mixing valve for storage water heating unit

Order no.	DN	G	Control range	$T_{0,max}$	V (l/min)	k_{VS}^1	k_{VS}^2
252.6003.104	20	1"	30 – 70 °C	100 °C	31,7	1,9	1,65
252.6003.330*	20	1"	30 – 70 °C	100 °C	27,5	-	1,65
252.6004.104	25	1 ¼"	30 – 70 °C	100 °C	43,3	2,6	2,25
252.6023.104**	20	1"	20 – 40 °C	80 °C	31,7	1,9	1,65
252.6024.104**	25	1 ¼"	20 – 40 °C	80 °C	43,3	2,6	2,25

* With integrated check valve

** On request (successor versions see NovaMix Value 20 – 50 °C)

NovaMix Standard 70 FR (Fast Response) | Thermostatic mixing valve for continuous flow water heating

Order no.	DN	G	Control range	$T_{0,max}$	V (l/min)	k_{VS}^1	k_{VS}^2
252.6043.104	20	1"	30 – 70 °C	100 °C	18,3	1,1	0,7

NovaMix Standard 70 FS (Fail Safe) | Thermostatic mixing valve | Special design with anti-scalding protection in the event of failure of the cold water supply for storage water heating units

Order no.	DN	G	Control range	$T_{0,max}$	V (l/min)	k_{VS}^1	k_{VS}^2
252.6003.107	20	1"	30 – 70 °C	100 °C	31,7	1,9	1,65
252.6004.107	25	1 ¼"	30 – 70 °C	100 °C	43,3	2,6	2,25

V = Volume obtained at $\Delta p = 1,0$ bar (without check-valve)

k_{VS}^1 = without check-valve

k_{VS}^2 = with check-valve

NOVAMIX STANDARD | THERMOSTATIC MIXING VALVE

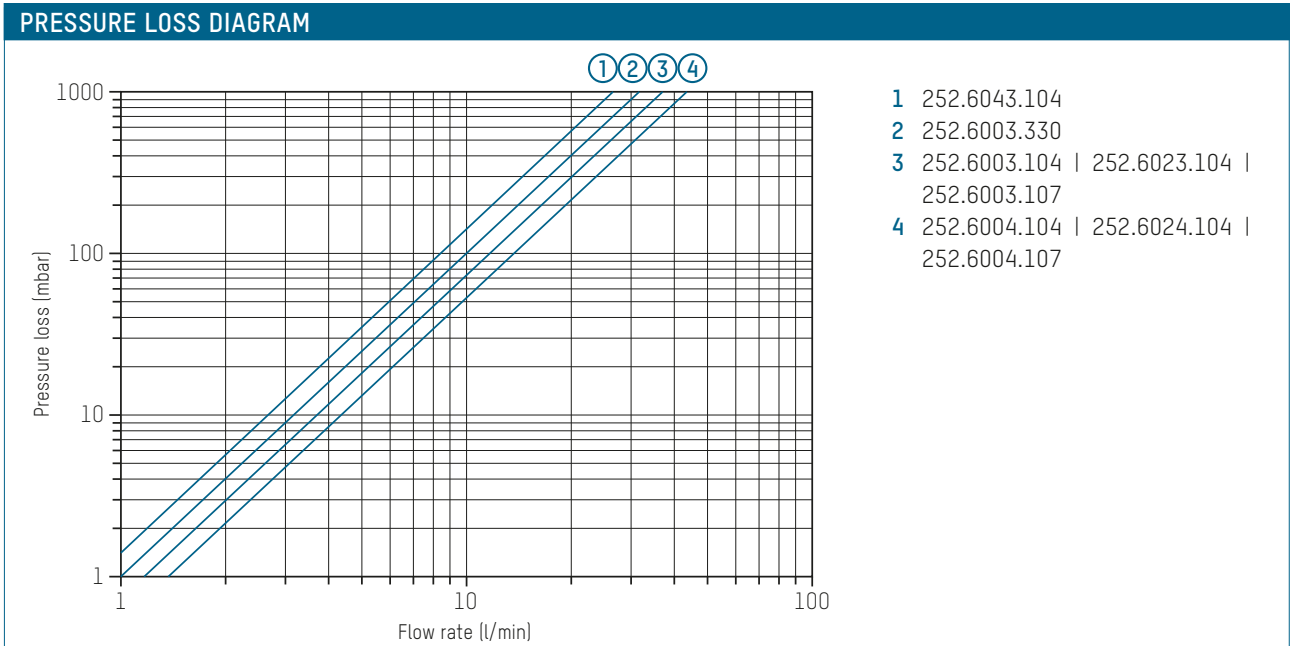

ACCESSORIES



INSULATION BOX

Order no.	DN
296.2326.000	20
296.2327.000	25



CHECK-VALVE

Operating temperature $T_{0 \max}$: 95 °C, operating pressure $P_{0 \max}$: 10 bar
For insertion in the screw connection at the cold and hot water inlets.

Order no.	Fits to order no.
296.5203.003	252.6003.XXX 252.6023.104 252.6043.104
296.5204.003	252.6004.XXX 252.6024.104



PRECISION THERMOMETER, QUICK RESPONSE

Fits in 1/2" T-piece, Indication range: 0 – 80 °C (accuracy class 2,5 within the range 40 – 60 °C), Sensor tube stainless steel, Sensor length: 39 mm

Order no.	R
296.5212.003	1/2"

SCREW CONNECTIONS

You will find various suitable screw connections in our price list.

SPARE PARTS



THERMAL ELEMENT WITH REGULATING PISTON

Order no.	Description
298.5263.000	20 – 40 °C for NovaMix Standard 40
298.5262.000	30 – 70 °C for NovaMix Standard 70/70 FR
298.5264.109	30 – 70 °C for NovaMix Standard 70 FS

Subject to modification. 09/2024

CONTACT AND FURTHER INFORMATION

[TACONOVA.COM](https://www.taconova.com)

Taconova Group AG | Neunbrunnenstrasse 40 | CH-8050 Zürich | T +41 44 735 55 55 | F +41 44 735 55 02 | group@taconova.com
Taconova UK Limited | AMP Technology Centre | Brunel Way | Rotherham | S60 5WG | T +44 114 231 3700 | adminuk@taconova.com