

TACOVENT AIRSCOOP D

AIR SEPARATOR



Permanent air separation.

DESCRIPTION

The air separator is fitted in the inlet pipe immediately behind the heating source. This is the point with the highest concentration of air and gas driven out of the water.

The expansion occurring inside the AirScoop and the built-in deflectors speed up the process of separating air and water.

When combined with the float air vent TacoVent HyVent, this system ensures air separation as well as elimination.

TacoVent AirScoop DV is recommended for venting in vertical pipes. The air separated from the medium and collected in the bottle can be vented sporadically via the vent valve.

INSTALLATION POSITION

The horizontal variant may only be installed horizontally and the vertical variant may only be installed vertically. The direction of flow must be kept in mind.

ADVANTAGES

- High air separation capacity
- Strong robust design
- Service and maintenance-free structure
- Two models for horizontal or vertical installation
- Additional connection for safety valve available from dimension 3"

OPERATION

The air expelled from the water into the heating circuit enters the air separator device as air bubbles. The flow-deflector in the housing drives the air bubbles to the top. The collected air is either automatically vented via the TacoVent HyVent (AirScoop horizontal) or manually via the vent valve (AirScoop vertical). The air-separation capacity can be increased by installing a straight piece of piping of approx. 0.5 m in length upstream the separator.

BUILDING CATEGORIES

For pipe installations in heating area:

- Apartment blocks, housing estates, multiple dwelling units
- Residential care facilities, hospitals
- Administration and service buildings
- Hotels and restaurants
- School buildings and sports facilities
- Commercial and industrial buildings

SYSTEM/BASIC DIAGRAM

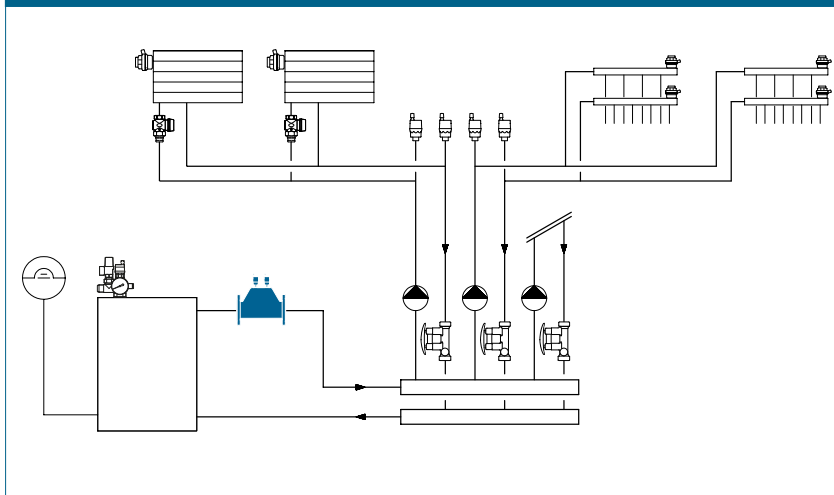

TACOVENT AIRSCOOP | AIR SEPARATOR

AIRSCOOP HORIZONTAL

SPECIFICATION TEXT

See www.taconova.com

TECHNICAL DATA

General

- Operating temperature $T_{0\text{ max}}$: 135 °C
with float vent valve $T_{0\text{ max}}$: 115 °C
- Operating pressure $P_{0\text{ max}}$: 10 bar

Material

- Housing in cast iron GG 25, lacquered

Fluids

- Heating water
(VDI 2035; SWKI BT 102-01;
ÖNORM H 5195-1)

TYPE OVERVIEW

TacoVent AirScoop DH | Air separator (horizontal), thread connection

Order no.	DN	Rp	Zeta ζ	k_v [m ³ /h]	Weight
243.5001.000	20	¾"	1,1	17,1	0,6 kg
243.5002.000	25	1"	1,0	28,8	0,8 kg
243.5003.000	32	1¼"	1,0	50,4	1,6 kg
243.5004.000	40	1½"	1,1	64,4	3,2 kg
243.5005.000	50	2"	0,84	114,0	3,2 kg
243.5006.000	65	2½"	0,67	237,0	6,8 kg

OPERATION PRINCIPLE

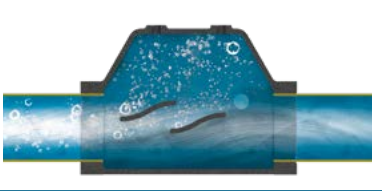

DIMENSIONAL DRAWING

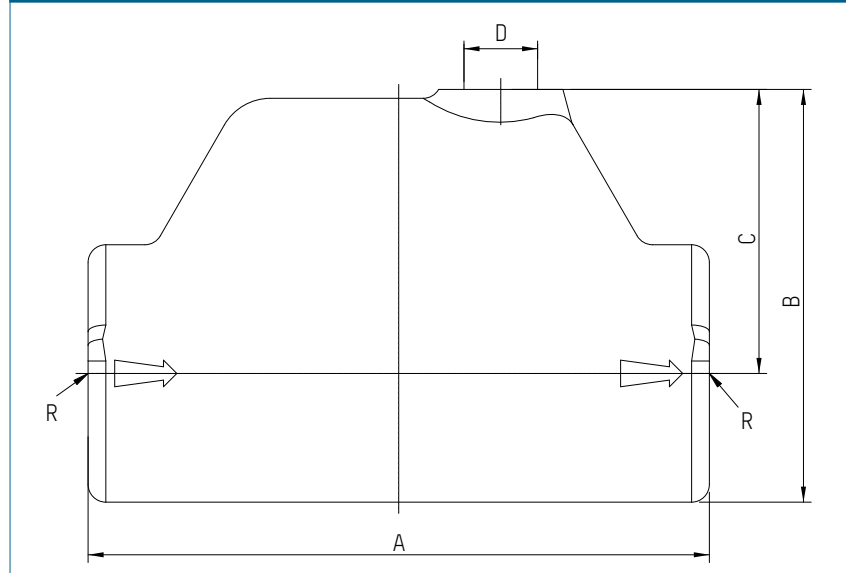

MEASUREMENT TABLE

TacoVent AirScoop DH | Air separator (horizontal)

Order no.	R	A	B	C	D
243.5001.000	Rp ¾"	110	69	48	Rp ¾"
243.5002.000	Rp 1"	120	79	55	Rp ¾"
243.5003.000	Rp 1¼"	140	93	64	Rp ¾"
243.5004.000	Rp 1½"	160	96	64	Rp ¾"
243.5005.000	Rp 2"	228	120	80	Rp ¾"
243.5006.000	Rp 2½"	235	144	95	Rp ¾"

ACCESSORIES



TACOVENT HYVENT

See separate data sheet

Order no.	DN	G	Version
242.5072.001	10	¾"	without automatic check valve
242.5072.002	10	¾"	with automatic check valve

TACOVENT AIRSCOOP D | AIR SEPARATOR

AIRSCOOP VERTICAL

SPECIFICATION TEXT

See www.taconova.com

TECHNICAL DATA

General

- Operating temperature $T_{0,max}$: 160 °C
- Operating pressure $P_{0,max}$: 8 bar

Material

- Black steel, stove enamelled

Fluids

- Heating water
(VDI 2035; SWKI BT 102-01;
ÖNORM H 5195-1)
- Water and proprietary additives
used against corrosion and freezing
up to 50%

TYPE OVERVIEW

TacoVent AirScoop DV | Ventilating flask (vertical)

Order no.	DN	G	k_v (m ³ /h)
296.7043.000	25	1"	11,1

DIMENSIONAL DRAWING



OPERATION PRINCIPLE



MEASUREMENT TABLE

TacoVent AirScoop DV | Ventilating flask, vertical

Order no.	G × G	Ø	L
296.7043.000	1"×1"	60,3 mm	301